

BROAD
Combats
POLLUTION



BROAD CLEAN AIR 400-677-6666

AIRPRO MASK

BROAD Clean Air Product AirPro Collection

Filter PM2.5 by 99.9%

Protection for renovation workers,
welders and miners against silicosis,
Prevention of cross-infection in hospitals,
Protection for joggers against exhaust fumes.

Model: FB2



Auto particle-filtering respirator
Standard: GB2626-2006 KN95

BROAD CLEAN AIR TECHNOLOGY
远大洁净空气科技有限公司

Sales: 400-677-6666 Service: 400-883-9333
www.broadair.net BROAD Town, Changsha, China

AIRPRO MASK

Get rid of air pollution in any polluted environment

Today, there are many kinds of wearable products in the world to counter dirty air, but few of them are truly useful. The BROAD AirPro Mask is an ultra-light rechargeable HEPA filter that everyone can afford. It can filter PM2.5 by 99.9%, protecting people from air pollution anywhere. In addition, it can increase breathing volume, and make people feel more refreshed and energetic. The compact BROAD AirPro Mask provides a shelter from the smog, and can be relied on by miners, construction workers, and others who work in a polluted environment. It can also protect medical staff from infectious diseases, and offers great hope for respiratory patients



Onsite work
Welders
Miners
Renovation workers



Hospitals
Doctors
Nurses
Respiratory patients



Sports
Running
Cycling
Fitness & Exercise



Smoggy Days
Outdoors
Indoors
In-vehicle

■ Structural Diagram

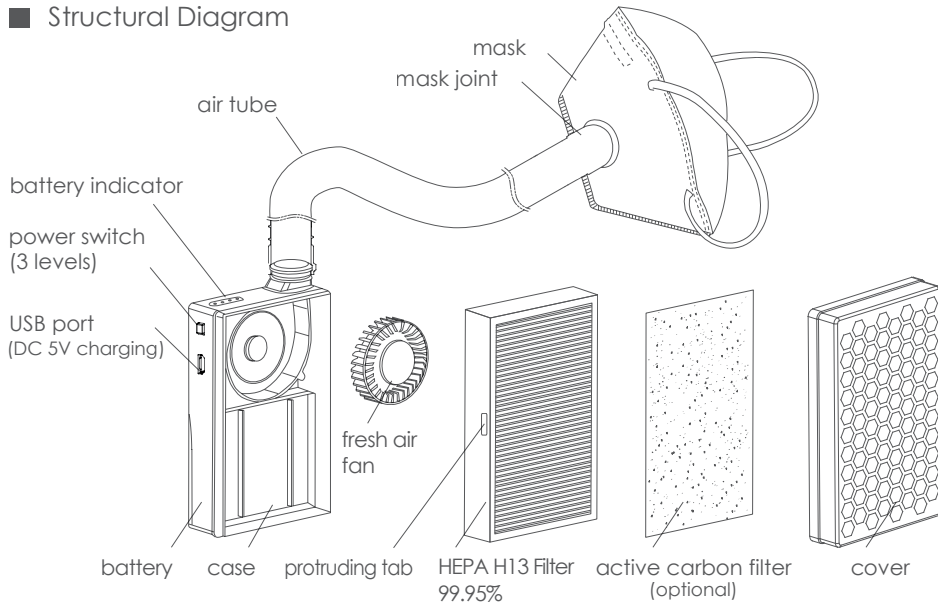

■ Standard Accessories

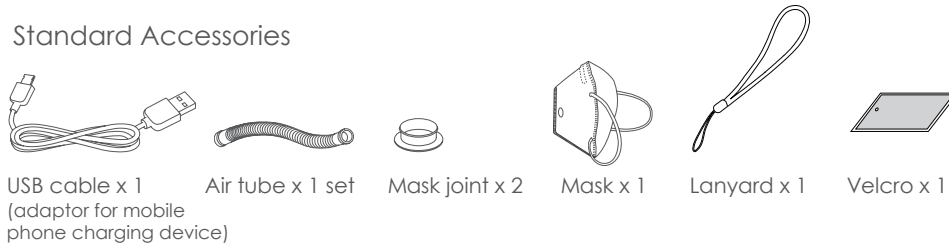

■ Troubleshooting

No.	Problem	Cause	Solution
1	Insufficient air volume	The HEPA filter is blocked	Replace the HEPA filter
2	The fan does not work	The fan or circuit board is damaged, the battery is dead, or the battery separation film is not removed	Repair or replace it, charge the battery or remove the battery separation film
3	Charging failure	The circuit board or USB cable or adaptor is damaged	Replace or repair it
4	The HEPA filter does not fit	The HEPA filter is backward	Put the protruding tab side upwards
5	The air tube is leaking	The air tube is aged or broken	Replace it

■ Parameter Table

Item	Level 1	Level 2	Level 3
Air Volume m ³ /h	2	3	4
Power W	0.6	0.9	1.3
Noise dB(A)	27	30	33
Battery	3.7V lithium battery		
Filtration Efficiency	Filter PM2.5 by 99.9%		

■ Air Volume Adjustment

(press the power switch for 2 secs to turn on)

- Remove the battery separation film before use for the first time
- Level 1 and Level 2 are for daily use
- Level 3 for physical labor and sports
- Suggestion for first time wearing: run the AirPro for 1~2 hours to sufficiently clean out before wearing (with air tube and mask connected)

■ Mask Replacement

- Prepare a new mask and draw a □12~14mm circle on the left or right side near the nostril
- Fold the circle in half and cut the hole with scissors
- Connect the mask to the mask joint and air tube

■ Regular Wearing Method

- Attach the AirPro to the lanyard and hang it on your chest, put on the face mask with the air tube connected
- When the outdoor temperature is low, the main unit should be put in the pocket or hung on the chest to reduce the discomfort caused by cold air
- You can also remove the lanyard from the Velcro and attach the Velcro to your helmet for easier work

■ HEPA Filter Replacement

(after shutdown and power off)

- When the air volume is less than 70%, the HEPA filter needs to be replaced
- Replace the HEPA filter: Open the cover, take out and replace the HEPA filter. The HEPA filter should be replaced after 500 hours of use. When installing the HEPA filter, the protruding tab must point upward, otherwise the HEPA filter will not fit
- Activated carbon is useful for absorbing toxic chemical fumes or gas, but it is very thin and easy to saturate. It should be replaced after 100 ~ 200 hours of use. For painters and renovation workers, replace every 2~5 days
- The mask needs to be cleaned or replaced if it is dirty

■ Warranty

- 1-year warranty from the date of purchase. For problems caused by design, manufacturing or transportation from factory, free repair or replacement will be provided
- If the user is unable to provide a valid proof of purchase, the warranty period should be extended by 3 months from the date of production shown on the unit
- If the AirPro was damaged due to inappropriate use or storage, or the sticker was torn off, there will be a charge for repair

■ Maintenance

- Replace the HEPA filter when needed
- Keep the AirPro away from liquid, and avoid exposure to rain
- Avoid hitting, dropping or impacting the AirPro
- Design life: 20 years (the bearing may need to be replaced during this period)

Quality Certificate/ Warranty Card

Name: AirPro Mask

Model: FB2

Serial Number:

Inspector:

Date of Purchase:

Shop:

Seller:



BROAD
Combats
POLLUTION



BROAD CLEAN AIR 400-677-6666



AIRPRO CAR

BROAD Clean Air Product AirPro Collection

Filter PM2.5 by 99%

Reliable travel partner,
Clean air everywhere you go!

Model : FC3

Especially suitable for:
Car, hotel for biz travel

Air volume 30 m³/hr
Power consumption 7W · h/m³

Filter PM2.5 by 99%

HEPA to be replaced every
1,000 ~ 2,000 hrs



Standard: GB/T18801-2015



BROAD CLEAN AIR TECHNOLOGY
远大洁净空气科技有限公司

Sales: 400-677-6666 www.broadair.net

Service: 400-883-9333 BROAD Town, Changsha, China

■ Structural Diagram

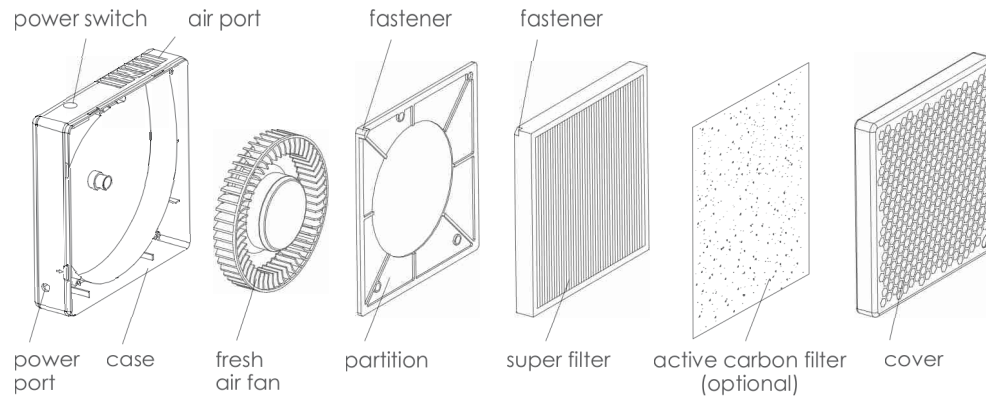

■ Standard Accessories

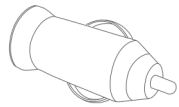

DC 5V car charger x1

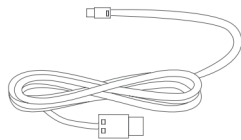

USB cable x1

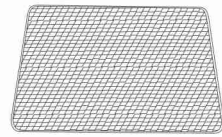

non-slip mat x 1 (for car)

■ Troubleshooting

No.	Problem	Cause	Solution
1	Insufficient air volume	The filter is blocked	Replace the super filter
2	The exit grille is stained	The polluted air flows back (if the filter is faulty, there is likely dirt in the fan)	Clean it with towel (avoid water from entering the fan)
3	Button failure	The button is stuck or the wire is broken	Repair or replace it
4	The fan doesn't work	The power plug is loose and has poor connection	Unplug and plug back in
		The fan or the circuit board is broken	Repair or replace it
		The AirPro automatically powered off after 4-hour continuous operation	Re-start

■ Safety Instruction

To avoid danger or improper use, please read the following safety instructions carefully before use:

- Proper temperature: -10°C ~ 45°C. Power off when at hazardous areas such as gas stations
- Avoid direct sunlight when not driving, power off quickly if a failure occurs
- Please use the original accessories, accessories from other brands may cause failure, fire or other dangers due to incompatibility
- To dispose of an AirPro product, do not dispose it with ordinary garbage. Take it to a qualified electrical waste station for recycling.

■ Parameter Table

Item	Level 1	Level 2	Level 3
Air Volume m ³ /h	10	20	30
Power W	2	3	7
Noise dB(A)	28	35	45
Battery	DC 5V		
Filter Efficiency	Filter PM2.5 by 99%		

■ Air Volume Adjustment

- Level 1 (blue light): Suitable for sleep
- Level 2 (green light): Suitable for room
- Level 3 (yellow light): High air volume (Note the AirPro will be more audible at this setting). Suitable for car

■ Power Source

- Car charger socket: DC 5V, 2.0A (In-car)
- Standard mobile-phone charger: DC 5V, 2.0A (In-room)

■ Warranty

- 1-year warranty from the date of purchase. For problems caused by design, manufacturing or transportation from factory, free repair or replacement will be provided
- If the user is unable to provide a valid proof of purchase, the warranty period should be extended by 3 months according to the production date shown on the unit
- If the AirPro was damaged due to inappropriate use or storage, or the sticker was torn off, there will be a charge for repair

■ Filter Replacement

(after shutdown and power off)

- Replace after 1,000 ~ 2,000 hours of use
- In-car: 1 year;
In-room (non-stop use): 3 months
- Activated carbon is useful for absorbing toxic chemical fumes or gas, but it is very thin and easy to saturate. The carbon filter should be replaced every month. For a new car or newly renovated room, replace it every week

■ Maintenance

- Keep the AirPro away from liquid, and avoid exposure to rain
- Avoid hitting, dropping or impacting the AirPro
- Design life: 20 years (the bearing may need to be replaced during this period)

Quality Certificate/ Warranty Card

Name: AirPro Car

Model: FC3

Serial Number:

Inspector:

Date of Purchase:

Shop:

Seller:



BROAD
Combats
POLLUTION



BROAD CLEAN AIR 400-677-6666



AIRPRO CO₂ SENSOR

BROAD Clean Air Product AirPro Collection

Filter PM2.5 by 99%

Clean, fresh air
Healthy, safe life

Hazard of O₂ deficiency:

An increase in CO₂ density can lead to O₂ deficiency. Living with insufficient O₂ increases heart load, lowers blood circulation and harms our organs, especially for children and elders

Prevent car accidents by monitoring CO₂

CO₂ density could increase quickly in the limited space because of human breath. Hypoxia makes people sleepy and may cause accidents

Especially suitable for:

Car, hotel for biz travel

Air volume 30 m³/hr

Power consumption 7W · h/m³

Monitor CO₂ Concentration

Filter PM2.5 by 99%

Super filter to be replaced every
1,000 ~ 2,000 hrs



Standard: GB/T18801-2015



BROAD CLEAN AIR TECHNOLOGY
远大洁净空气科技有限公司

Sales: 400-677-6666 www.broadair.net

Service: 400-883-9333 BROAD Town, Changsha, China

Model :
FC2

Structural Diagram

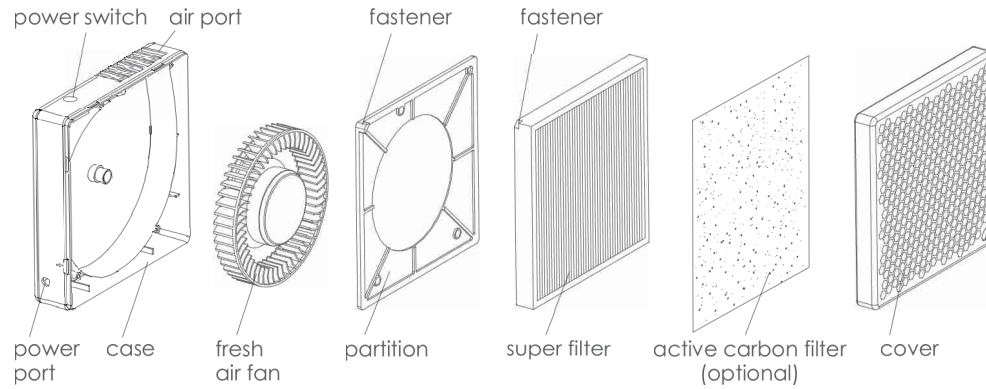

Standard Accessories

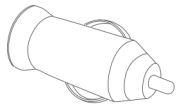

DC 5V car charger x1

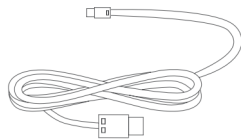

USB cable x1

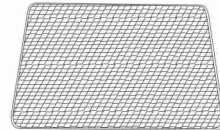

non-slip mat x 1 (for car)

Troubleshooting

No.	Problem	Cause	Solution
1	Insufficient air volume	The filter is blocked	Replace the super filter
2	The exit grille is stained	The polluted air flows back (if the filter is faulty, there is likely dirt in the fan)	Clean it with towel (avoid water from entering the fan)
3	Button failure	The button is stuck or the wire is broken	Repair or replace it
4	The fan doesn't work	The power plug is loose and has poor connection	Unplug and plug back in
		The fan or the circuit board is broken	Repair or replace it
5	Inaccurate CO ₂ data	The AirPro was automatically power off after 4-hour continuous operation	Re-start
		There is a deviation of the nominal value	Turn on the AirPro when the natural ventilation is good. Wait for 2 minutes, and then press the power switch for 5 seconds. After 2 beeps, press the switch again to restore normal status

Safety Instruction

To avoid danger or improper use, please read the following safety instructions carefully before use:

- Proper temperature: -10°C ~ 45°C. Power off when at hazardous areas such as gas stations
- Avoid direct sunlight when not driving, power off quickly if a failure occurs
- Please use the original accessories, accessories from other brands may cause failure, fire or other dangers due to incompatibility
- To dispose of an AirPro product, do not dispose it with ordinary garbage. Take it to a qualified electrical waste station for recycling.

Parameter Table

Item	Level 1	Level 2	Level 3
Air Volume m ³ /h	10	20	30
Power W	2	3	7
Noise dB(A)	28	35	45
Battery	DC 5V		
Filter Efficiency	Filter PM2.5 by 99%		

CO₂ Laser Detector



Real-time display of CO₂ concentration

Oxygen deficiency Reminder

CO₂ ppm ≤ 1200 Sufficient oxygen

CO₂ ppm ≤ 2400 Oxygen deficiency

CO₂ ppm > 2400 Severe oxygen deficiency

Air Volume Adjustment

- Level 1 (blue light): Suitable for sleep
- Level 2 (green light): Suitable for room
- Level 3 (yellow light): High air volume (Note the AirPro will be more audible at this setting). Suitable for car

Power Source

- Car charger socket: DC 5V, 2.0A (In-car)
- Standard mobile-phone charger: DC 5V, 2.0A (In-room)

Filter Replacement

(operate after powering off)

- When the air volume is less than 70% of the filter, the filter needs to be replaced
- Replace the super filter: Open the cover, take out and replace the super filter. When installing, the fastener of the filter must be aligned with the fastener on the partition, otherwise the cover will not fit

Filter Replacement Period

- Replace after 1,000 ~ 2,000 hours of use
- In-car: 1 year;
- In-room (non-stop use): 3 months
- Activated carbon is useful for absorbing toxic chemical fumes or gas, but it is very thin and easy to saturate. The carbon filter should be replaced every month. For a new car or newly renovated room, replace it every week

Warranty

- 1-year warranty from the date of purchase. For problems caused by design, manufacturing or transportation from factory, free repair or replacement will be provided
- If the user is unable to provide a valid proof of purchase, the warranty period should be extended by 3 months according to the production date shown on the unit
- If the AirPro was damaged due to inappropriate use or storage, or the sticker was torn off, there will be a charge for repair

Maintenance

- Keep the AirPro away from liquid, and avoid exposure to rain
- Avoid hitting, dropping or impacting the AirPro
- Design life: 20 years (the bearing may need to be replaced during this period)

Quality Certificate/ Warranty Card

Name: AirPro CO₂ Sensor

Model: FC2

Serial Number:

Inspector:

Date of Purchase:

Shop:

Seller:



BROAD
Combats
POLLUTION



BROAD CLEAN AIR 400-677-6666



AIRPRO HOME

BROAD Clean Air Product AirPro Collection

Filter PM2.5 by 99%

AirPro Home:
Protecting your family's health

Model : FD2



Standard: GB/T18801-2015



BROAD CLEAN AIR TECHNOLOGY
远大洁净空气科技有限公司

Sales: 400-677-6666 www.broadair.net

Service: 400-883-9333 BROAD Town, Changsha, China

Air Volume **200 m³/hr**

Area Coverage **10~20 m²**

Filter PM2.5 by **99%**

Super Filter to be Replaced:
every 3,000 hrs

■ Structural Diagram

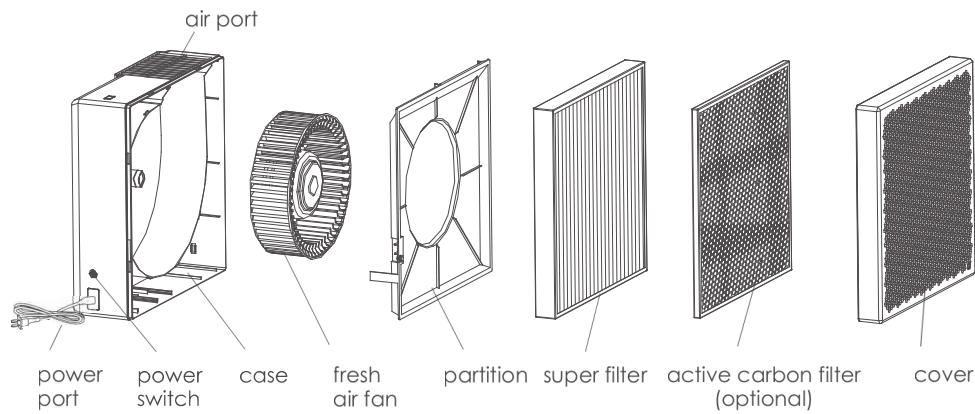

■ Troubleshooting

No.	Problem	Cause	Solution
1	Insufficient air volume	The filter is blocked	Replace the super filter
2	The outlet grille is stained	The polluted air flows back (if the filter is faulty, there is likely dirt in the fan)	Clean with a towel (to prevent water from entering the fan)
3	Button failure	The button is stuck or the wire is broken	Repair or replace it
4	The fan doesn't work	The power plug is loose and has poor contact	Unplug and plug back in
		The fan or the circuit board is broken	Repair or replace it

■ Parameter Table

Item	Level 1	Level 2	Level 3	Level 4	Level 5	Level 6
Air Volume m ³ /h	60	80	110	140	160	200
Power W	5	6	8	12	15	20
Noise dB(A)	25	30	36	40	42	46
Battery	AC 100~220V					
Filter Efficiency	Filter PM2.5 by 99%					

■ Air Volume Adjustment

Press the power switch to switch levels:

- Level 1 & 2 (blue light)
- Level 3 & 4 (green light)
- Level 5 & 6 (yellow light) :
High air volume (Note the AirPro will be more audible at this setting)

■ Warranty

- 1-year warranty from the date of purchase. For problems caused by design, manufacturing or transportation from factory, free repair or replacement will be provided
- If the user is unable to provide a valid proof of purchase, the warranty period should be extended by 3 months according to the production date shown on the unit
- If the AirPro was damaged due to inappropriate use or storage, or the sticker was torn off, there will be a charge for repair

■ Filter Replacement

(operate after shutdown and power off)

- When the air volume is less than 70% of the filter, the filter needs to be replaced
- Replace the super filter: Open the cover, take out and replace the super filter. The super filter should be replaced after 3,000 hours of use. When installing the super filter, the arrow direction should be inward
- Activated carbon is useful for absorbing toxic chemical fumes or gas, but it is very thin and easy to saturate. It should be replaced after 100 ~ 200 hours of use. For newly renovated room, replace it every week

■ Maintenance

- Replace the super filter when needed
- Keep the AirPro away from liquid
- Avoid hitting, dropping or impacting the AirPro
- Design life: 20 years (the bearing may need to be replaced during this period)

Quality Certificate/ Warranty Card

Name: AirPro Home

Model: FD2

Serial Number:

Inspector:



Date of Purchase:

Shop:

Seller:

BROAD
Combats
POLLUTION



BROAD CLEAN AIR 400-677-6666



AIRPRO SIMPLE

BROAD Clean Air Product AirPro Collection

Filter PM2.5 by 99%

Small, user-friendly, affordable
A must-have for temperate regions

Model : FE5



Fresh Air Volume 180 m³/hr

Area Coverage
20~40 m² per room
in mild climate areas

Filter PM2.5 by 99%

Fresh Air Ventilation

Coarse filter to be cleaned every 500 hrs
Super filter to be replaced every 3,000 hrs



Standard: GB/T18801-2015



BROAD CLEAN AIR TECHNOLOGY
远大洁净空气科技有限公司

Sales: 400-677-6666 www.broadair.net

Service: 400-883-9333 BROAD Town, Changsha, China



■ Structural Diagram

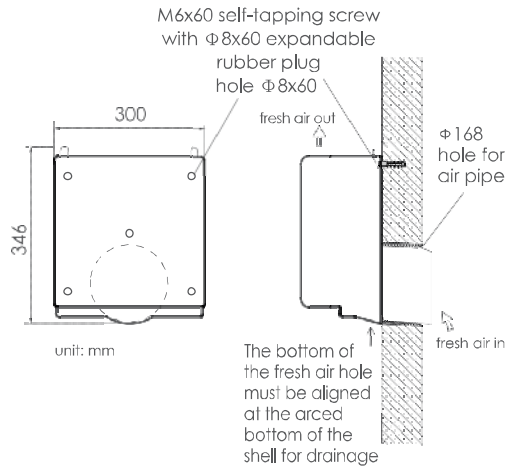
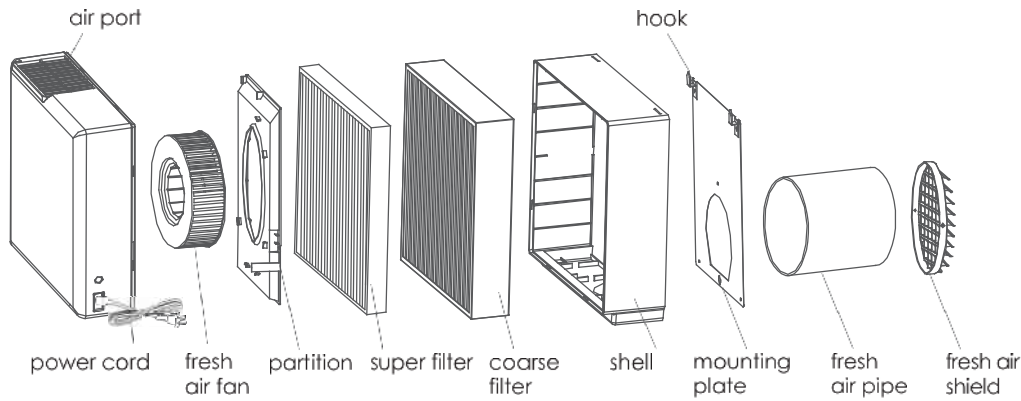

■ Installation Process

1. Confirm the installation location
2. Drill the fresh air hole. The external opening should be 5~10mm lower than the internal opening to prevent rain penetration
3. Install the fresh air pipe and the water shield
4. Fill the gap between the air pipe and the wall hole with polyurethane, and keep it sealed
5. Drill 5 holes for the retaining bolts as per the mounting plate and the fresh air pipe
6. Knock the rubber plugs into the retaining bolt holes and screw down the bolts
7. Hang the machine on the mounting plate

■ Troubleshooting

No.	Problem	Cause	Solution
1	Insufficient air volume	The filter is blocked	Replace the super filter
2	The outlet grille is stained	The polluted air flows back (if the filter is faulty, there is likely dirt in the fan)	Clean with a towel (to prevent water from entering the fan)
3	Button failure	The button is stuck or the wire is broken	Repair or replace it
4	The fan doesn't work	The power plug is loose and has poor connection	Unplug and plug back in
		The fan or the circuit board is broken	Repair or replace it

■ Parameter Table

Item	Level 1	Level 2	Level 3	Level 4	Level 5	Level 6
Air Volume m ³ /h	60	80	110	140	160	180
Power W	5	6	8	12	15	18
Noise dB(A)	26	30	36	40	42	46
Battery	AC 220V					
Filter Efficiency	Filter PM2.5 by 99%					

■ Airflow Adjustment

• Power switch

- Level 1 (blue light): Suitable for sleep
- Level 2 (green light): Suitable for room
- Level 3 (yellow light): High air volume (Note the AirPro will be more audible at this setting)

■ Warranty

- 1-year warranty from the date of purchase. For problems caused by design, manufacturing or transportation from factory, free repair or replacement will be provided
- If the user is unable to provide a valid proof of purchase, the warranty period should be extended by 3 months according to the production date shown on the unit
- If the AirPro was damaged due to inappropriate use or storage, or the sticker was torn off, there will be a charge for repair

■ Filter Replacement

(operate after powering off)

- When the air volume is less than 70% of the filter, the filter needs to be replaced
- Coarse filter washing: hold the machine upwards 4mm to remove it from the wall, take out the stainless steel coarse filter from the back of the machine to wash, dry and re-install. The coarse filter should be cleaned after 500 hours of use, or every half a month in heavily polluted areas
- Super filter replacement: remove the machine from the wall, take out the stainless steel coarse filter first, and then the super filter for replacement. The super filter should be replaced after 3,000 hours of use. When installing the super filter, the arrow direction should be inward.

■ Maintenance

- Design life: 20 years (the bearing may need to be replaced during this period)
- Recommended maintenance:
 1. Wash the coarse filter every month;
 2. Replace the super filter every four months;
 3. Check the filtration efficiency and ventilation effect regularly
- Service: 4100-833-9333
- Web: www.broadair.net

Quality Certificate/ Warranty Card

Name: AirPro Simple

Model: FE5

Serial Number:

Inspector:

Date of Purchase:

Shop:

Seller:



BROAD
Combats
POLLUTION



BROAD CLEAN AIR 400-677-6666



AIRPRO FRESH

BROAD Clean Air Product AirPro Collection

Filter PM2.5 by 99%

Fresh air in every season,
Easily installed and energy efficient

Model: FE6



Standard: GB/T18801-2015



BROAD CLEAN AIR TECHNOLOGY
远大洁净空气科技有限公司

Sales: 400-677-6666

www.broadair.net

Service: 400-883-9333

BROAD Town, Changsha, China



Fresh Air Volume 130 m³/hr

Area Coverage

20~40 m² per room

Filter PM2.5 by 99%

Fresh Air Ventilation

Heat Recovery Efficiency 60%

Coarse filter to be cleaned every 500 hrs

Super filter to be replaced every 3,000 hrs

Structural Diagram

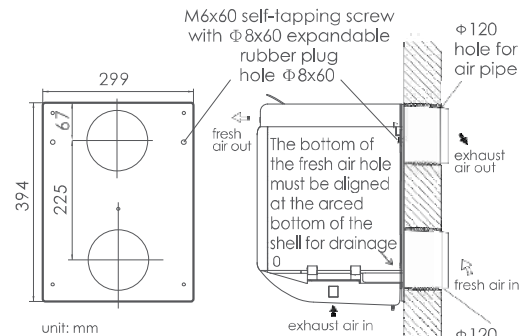
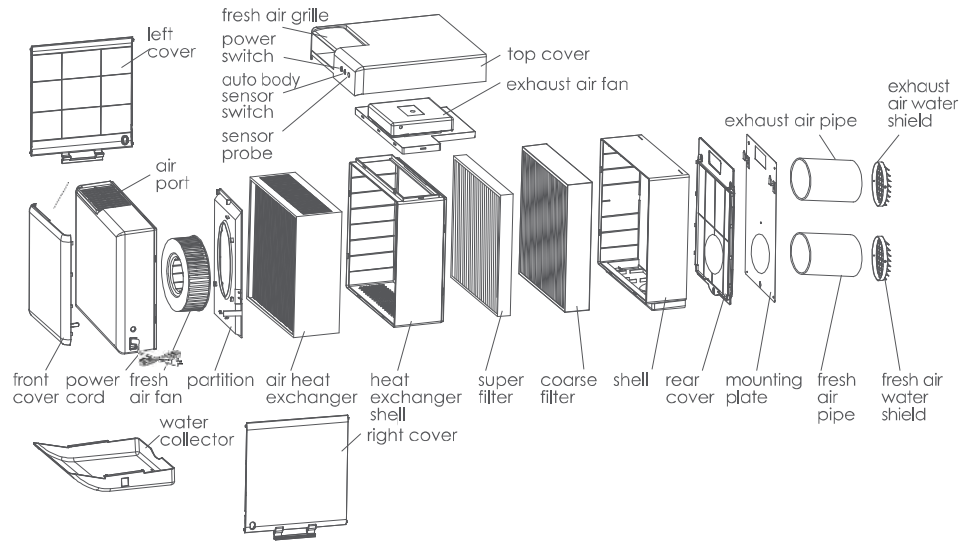

Installation Process

1. Confirm the installation location
2. Drill the fresh and exhaust air hole. The external openings of the holes should be 5~10mm lower than the internal openings to prevent rain penetration
3. Install the fresh air pipe, exhaust air pipe, and water shields
4. Fill the gap between the air pipe and the wall hole with polyurethane, and keep it sealed
5. Locate holes as per the mounting plate and drill them out
6. Fix the mounting plate horizontally with 2 expandable bolts and 5 steel bolts
7. Hang the machine on the mounting plate

Troubleshooting

No.	Problem	Cause	Solution
1	Insufficient air volume	The filter is blocked	Replace the super filter
2	The outlet grille is stained	The polluted air flows back (if the filter is faulty, there is likely dirt in the fan)	Clean with a towel (to prevent water from entering the fan)
3	Button failure	The button is stuck or the wire is broken	Repair or replace it
4	The fan doesn't work	The power plug is loose and has poor connection	Unplug and plug back in
		The fan or the circuit board is broken	Repair or replace it
5	Indicator light flashes	The water collector is full of condensate water	Draw out the water collector and empty it

Parameter Table

Item	Level 1	Level 2	Level 3	Level 4	Level 5	Level 6
Air Volume m ³ /h	50	70	80	90	110	130
Power W	7	11	15	21	28	31
Noise dB(A)	30	40	45	50	52	53
Battery	AC 220V					
Filter Efficiency	Filter PM2.5 by 99%					

Airflow Adjustment & Auto Shut-off

- Power Switch:
 - Level 1 (blue light): Suitable for sleep
 - Level 2 (green light): Suitable for room
 - Level 3 (yellow light): High air volume (Note the AirPro will be more audible at this setting)
- Automatic Body Sensor Auto-off 4 hrs after people leave (white light)
- Auto-off 12 hrs after people leave (orange light)
- Auto-off 24 hrs after people leave (red light)
- Always on (light off)
- Sensor probe: sensing distance <5m from human body

Warranty

- 1-year warranty from the date of purchase. For problems caused by design, manufacturing or transportation from factory, free repair or replacement will be provided
- If the user is unable to provide a valid proof of purchase, the warranty period should be extended by 3 months according to the production date shown on the unit
- If the AirPro was damaged due to inappropriate use or storage, or the sticker was torn off, there will be a charge for repair

Filter Replacement

(operate after powering off)

- When the air volume is less than 70% of the filter, the filter needs to be replaced
- Coarse filter washing: hold the machine upwards 4mm to remove it from the wall, take out the stainless steel coarse filter from the back of the machine to wash, dry and re-install. The coarse filter should be cleaned after 500 hours of use, or every half a month in heavily polluted areas
- Super filter replacement: remove the machine from the wall, take out the stainless steel coarse filter first, and then the super filter for replacement. The super filter should be replaced after 3,000 hours of use. When installing the super filter, the arrow direction should be inward.

Maintenance

- Design life: 20 years (bearings may need to be replaced during this period)
- Recommended maintenance:
 1. Wash the coarse filter every month;
 2. Replace the super filter every four months;
 3. Check the filtration efficiency and ventilation effect regularly
- Service: 4100-833-9333
- Web: www.broadair.net

Quality Certificate/ Warranty Card

Name: AirPro Fresh

Model: FE6

Serial Number:

Inspector:

Date of Purchase:

Shop:

Seller:

